

## Rotoflux per aria, vuoto e olio idraulico

Rotoflux for air, vacuum and hydraulic oil

Rotoflux für Luft, Vakuum und Hydrauliköl

Rotoflux para aire, vacío y aceite hidráulico



1/8" ÷ 2"

Aria / Air Luft / Aire	10 bar / 145 PSI	95°C / 203°F	  G/m <sup>3</sup> RPM
Vuoto / Vacuum Vakuum / Vacío	95 kPa / 28" Hg		
1/8" : 1 1/2" ÷ 50 bar / 725 PSI	2" ÷ 40 bar / 580 PSI		
Olio idraulico / Hydraulic oil / Hydrauliköl / Aceteite Hidraulico	1/4" : 3/4" ÷ 3.500 1" ÷ 3.000 1 1/4" : 1 1/2" ÷ 2.500 2" ÷ 1.500		



### ROTOFLUX PER ARIA, VUOTO E OLIO IDRAULICO

I giunti della serie T sono disponibili con due tipi di tenute meccaniche bilanciate-microlappate:

- Tenute N (Tenute Normali) in grafite contro carburo per applicazioni con aria, vuoto e olio idraulico press. max 20 bar
- Tenute D (Tenute Dure) in carburo contro carburo per applicazioni con olio idraulico.

Il modello T06, molto compatto, è provvisto di una molla centrale ed è disponibile con Tenute N in acciaio inox contro grafite e Tenute D in acciaio inox contro bronzo.

Non utilizzare i giunti alle massime condizioni di esercizio senza consultare ROTOFLUX.



### ROTOFLUX FOR AIR, VACUUM AND HYDRAULIC OIL

The unions of the model T are provided with two different micro-lapped sealing assemblies:

- N model (Standard) with carbon graphite to carbide seals, for air, vacuum and hydraulic oil at 20 bar max pressure.
- D model (Heavy duty) with carbide to carbide seals for hydraulic oil applications.

The model T06, very short, is provided with a center spring and N seal in stainless steel against carbon graphite or with D seal in stainless steel against bronze. Do not use the unions at max application limits without consulting ROTOFLUX.



### ROTOFLUX FÜR LUFT, VAKUUM UND HYDRAULIKÖL

Die Drehdurchführungen dieses Modells T sind mit ausgeglichenen, feingeläpften mechanischen Dichtungen in zwei Ausführungen lieferbar:

- N-Dichtungen (Normale Ausführung) aus Kohlegraphit gegen Karbid, für Anwendungen mit Luft, Vakuum, Hydrauliköl mit Druck bis 20 bar.
- D-Dichtungen (für hohe Beanspruchungen) aus Karbid gegen Karbid, für Anwendungen mit Hydrauliköl.

Das sehr kompakte Modell T06 ist mit einer zentralen Feder ausgestattet, mit Dichtungspaarung Edelstahl gegen Kohlegraphit, bzw. Edelstahl gegen Bronze ausgerüstet.

Die Drehdurchführungen nicht unter den maximalen Betriebsbedingungen verwenden, ohne sich vorher mit dem ROTOFLUX Kundendienst abgesprochen zu haben.



### ROTOFLUX PARA AIRE, VACIO Y ACEITE HIDRÁULICO

Los modelos ROTOFLUX T están disponibles en dos versiones de sellos mecánicos equilibrados y lapeados:

- Sella N (Sella estándar) de grafito contra carburo para aplicaciones con aire y vacío y aceite hidráulico presión max 20 bar.
- Sella D (Sella duro) de carburo contra carburo para aplicaciones con aceite hidráulico.

El modelo compacto T06 dispone de un único muelle central y de sellos de acero inoxidable contra grafito o de acero inoxidable contra bronce.

En el caso de que su aplicación esté al límite de las características técnicas, les rogamos se pongan en contacto el departamento técnico de ROTOFLUX.

**ROTO  
FLUX**

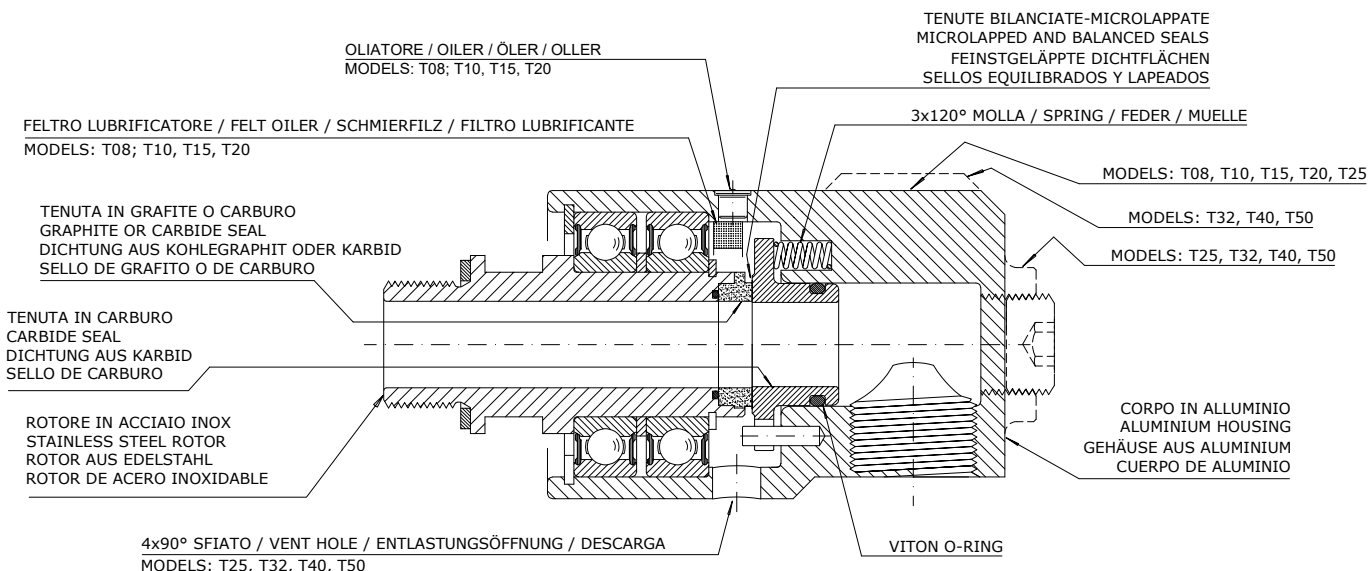

MODELS: T06, T08, T10, T15, T20, T25

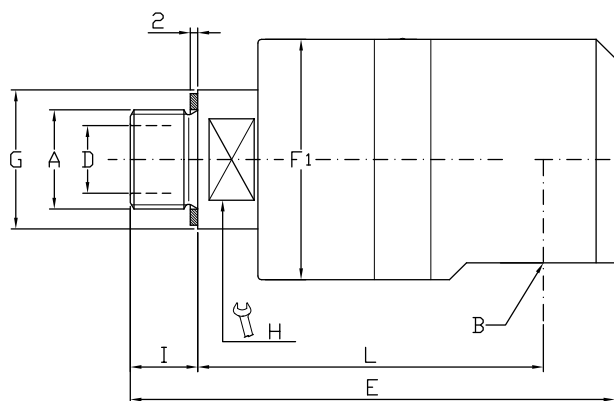

MODELS: T32, T40, T50

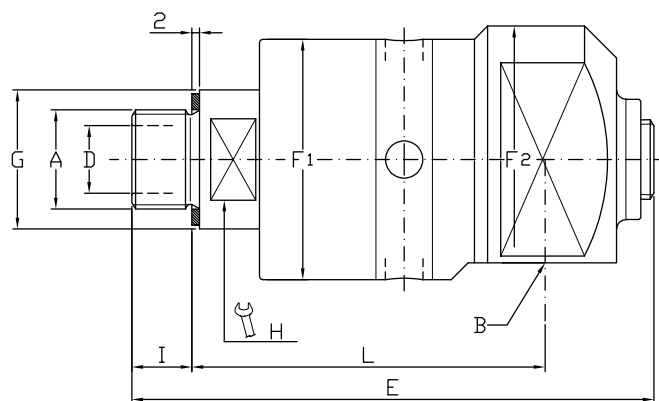

Ordering code		Giunti a un passaggio - Single passage unions Einweg Drehdurchführungen - juntas a vía simple										
Air - Vacuum	Hydraulic Oil	A	B	ø D	E	ø F1	ø F2	ø G	H	I	L	Kg
T06-302-01R	T06-301-01R	G 1/4" RH	G 1/8"	3,5	72	29	-	20	15	11	53	0,2
T06-302-02L	T06-301-02L	G 1/4" LH										
T06-302-04R	T06-301-04R	M 10x1 PT.11	G 1/8"	4,0	73	29	-	17	13	11+3	51	0,2
T08-1302-01R	T08-1301-01R	G 1/4" RH	G 1/4"	7	89	43	-	20	17	11	68	0,4
T08-1302-02L	T08-1301-02L	G 1/4" LH										
T10-1302-01R	T10-1301-01R	G 3/8" RH	G 3/8"	9	98	43	-	25	17	13	73	0,4
T10-1302-02L	T10-1301-02L	G 3/8" LH										
T15-1302-01R	T15-1301-01R	G 1/2" RH	G 1/2"	13	112	54	-	30	24	13	82	0,7
T15-1302-02L	S15-1301-02L	G 1/2" LH										
T20-1302-01R	T20-1301-01R	G 3/4" RH	G 3/4"	18	130	64	-	37	30	16	94	1,2
T20-1302-02L	T20-1301-02L	G 3/4" LH										
T25-1302-01R	T25-1301-01R	G 1" RH	G 1"	23	149	69	-	45	36	20	105	1,5
T25-1302-02L	T25-1301-02L	G 1" LH										
T32-1302-01R	T32-1301-01R	G 1 1/4" RH	G 1 1/4"	31	181	85	94	55	46	22	119	3,9
T32-1302-02L	T32-1301-02L	G 1 1/4" LH										
T40-1302-01R	T40-1301-01R	G 1 1/2" RH	G 1 1/2"	36	208	101	109	60	50	24	132	5,1
T40-1302-02L	T40-1301-02L	G 1 1/2" LH										
T50-1302-01R	T50-1301-01R	G 2" RH	G 2"	48	223	112	119	70	60	25	139	6,8
T50-1302-02L	T50-1301-02L	G 2" LH										

### Sono disponibili filettature Metriche, NPT ed altre

Metric threads, NPT threads and other threads are available  
 Verfügbar sind metrische, NPT und andere Gewindeformen  
 Disponibles rosca métrica, NPT y otras, según necesidad