

# Serie D08

## Rotoflux doppio passaggio per aria e olio idraulico

Rotoflux double passage for air, vacuum and hydraulic oil





Rotoflux 2-Wege für Luft, Vakuum und Hydrauliköl

Rotoflux de doble vía para aire, vacío y aceite hidráulico



1/4"



Passaggio / Passage Kanal / Via				
Aria / Air Luft / Aire	B1 B2	10 bar / 145 PSI	10 bar / 145 PSI → 4.000 6 bar / 87 PSI → 7.000	30 μ (MAX 60)
Rotazione a secco / Dry run Trockenlauf / Rotaciones en seco	B1 B2	/	7.000	/
Olio Idraulico / Hydraulic oil Hydrauliköl / Aceteite Hidraulico	B1 B2	50 bar / 725 PSI	50 bar / 725 PSI → 0 5 bar / 72 PSI → 7.000	30 μ (MAX 60)
Rotazione a secco / Dry run Trockenlauf / Rotaciones en seco	B1 B2	/	NO 7.000	/



### ROTOFLUX DOPPIO PASSAGGIO PER ARIA, VUOTO E OLIO IDRAULICO

I giunti ROTOFLUX modello D08 con due passaggi indipendenti sono normalmente utilizzati su frizioni e cilindri rotanti idraulici e pneumatici. Nei due passaggi deve passare lo stesso fluido per evitare contaminazioni nel caso di perdite accidentali. Non utilizzare i giunti alle massime condizioni di esercizio senza consultare ROTOFLUX.



### ROTOFLUX DOUBLE PASSAGE FOR AIR, VACUUM AND HYDRAULIC OIL

The ROTOFLUX unions model D08 with two separate passages are used to operate clutches or rotating pistons with air or oil. The same type of fluid must be used for the two passages to avoid eventual mixture. Do not use the unions at max application limits without consulting Rotoflux.



### ROTOFLUX 2-WEGE FÜR LUFT, VAKUUM UND HYDRAULIKÖL

Die Drehdurchführungen des Modells D08 mit zwei unabhängigen Wegen werden normalerweise bei Bremsen, Kupplungen sowie hydraulischen und pneumatischen Drehzylindern verwendet. Es muss das gleiche Medium in beiden Wegen verwendet werden, um eventuellen Vermischungen vorzubeugen. Die Drehdurchführungen dürfen nicht unter den maximalen Betriebsbedingungen verwendet werden, ohne sich vorher mit dem ROTOFLUX Kundendienst abgesprochen zu haben.



### ROTOFLUX DE DOBLE VÍA PARA AIRE, VACÍO Y ACEITE HIDRÁULICO

El modelo ROTOFLUX D08 a dos vías independientes se utiliza generalmente en frenos, embragues y cilindros rotativos, hidráulicos o neumáticos. El mismo fluido debe pasar por las dos vías, ya que utilizando dos fluidos diferentes podrían mezclarse en caso de pérdida accidental de los sellos. En el caso de que su aplicación esté al límite de las características técnicas, pónganse en contacto con ROTOFLUX.

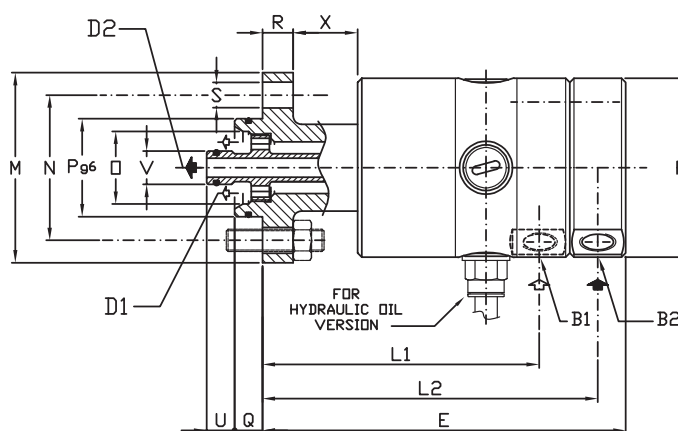
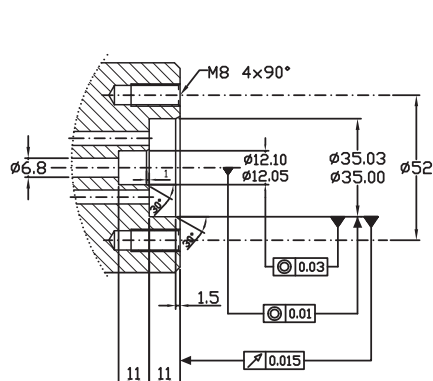

Ordering code		Giunto doppio passaggio - Double passage union 2-Wege Drehdurchführungen - Juntas doble vía																	
Air	Hydraulic oil	B1 - B2	D1	D2	E	øF	L1	L2	øM	øN	øO	øP g6	Q	R	øS	U	øV	X1	Kg
D08-1302-56F	D08-1306-56F	G 1/4"	40 mm <sup>2</sup>	ø 5 20 mm <sup>2</sup>	130	64	99	120	68	52	25	35	10	11	9 4x90°	10	12	23	1,5